



Key Features

- Dry running (zero oil mist/vapour)
- Cannot leak oil or run dry
- Suitable for prolonged leak conditions
- Compact, portable design
- Engineered for constant operation
- Integrated power switch/lead

Product Description

The EC5 Dry Running Compact Vacuum Pump is the result of development work in conjunction with leading Italian vacuum pump manufacturer DVP to produce a compact and portable dry running vacuum pump for applications such as bag/veneer pressing, general vacuum bagging and in-situ composites repair work where fully sealed vacuum bags or equipment cannot always be expected. In these cases, oil-free 'dry running' eliminates the problem of oil vapour emission or spillage often associated with oil-lubricated vacuum pumps when run in a leaking condition for long periods of time.

As well as composites applications, EC5 is suitable for a wide range of applications where an oil free, dry running pump is required.

The pump's quiet operation, continuous duty cycle, check-valve and completely mist free operation make it suitable for all environments, including manufacturing facilities, workshops, laboratories, schools and universities.

The underlying DVP pump technology is considered to be the best on the market offering an unrivalled combination of performance and reliability, backed by a 2-year warranty, whilst the rugged, mobile form factor provides maximum protection and practicality.

Recommended Uses

- Veneer pressing
- Bag pressing
- Vacuum bonding
- General vacuum bagging (see 'vacuum level')
- Vacuum bagging for 'in-situ' repair work

Oil-Free Operation

The dry running, oil-free design of the EC5 means that it is impossible for the pump to generate any oil mist or vapour, or for any oil to be emitted or spill from the pump during operation. It also makes it impossible for the pump to run out of oil due to oil spillage caused by prolonged use in leaking condition, making it suitable for applications where prolonged use against imperfectly sealed vacuum bags or equipment is likely.

Vacuum Level

Oil-free, dry running pumps do not achieve the very high levels of vacuum possible with oil lubricated pumps (such as DVP EC4 or EC20) but EC5 still achieves a final pressure of 120 mbar (90% vacuum) which is more than adequate for the general vacuum bagging, vacuum bonding, bag pressing and repair work it is designed for.

EC5 is not suitable, however, for applications requiring the highest possible levels of vacuum such as vacuum bagging out-of-autoclave prepregs, resin infusion and vacuum degassing. For these applications, we would recommend the DVP EC4 or EC20.

Size Capability

Despite its compact size, EC5 offers impressive performance with a free air displacement of >5m³ per hour, ensuring fast pull-down even on large vacuum bags. The only limiting factor on bag/component size is the amount of leakage the pump must overcome. For a typical reusable bag/veneer press operations, this means EC5 is comfortably suitable for project areas up to around 10m².

Portable Form Factor

EC5 is designed for portable use, wherever it is required. Its strong metal case protects it from accidental damage whilst its sturdy carry handle make it easy to move between locations.

The power lead features an inline IEC plug and socket which will disconnect rather than damage the pump if the cable is accidentally snagged.



Equipment & Features

- Integral non-return check valve
- Integrated power switch and IEC socket
- Exhaust silencer

Non-return Check Valve

An integrated check-valve prevents oil and air back-flow when the pump is switched off making the pump easier to use and protecting it from user error.

Note: The non-return valve is not 100% airtight and so if your process involves leaving a bag/equipment under vacuum with the pump switched off, you should isolate the pump using a vacuum valve.

Use as a Compressor

EC5 can also be used as a compressor by connecting equipment to the exhaust / outlet side. When used as a compressor, the maximum pressure is 0.8 bar.

Technical Specification

Property	Units	50Hz	60Hz
Manufacturer / Part Number		DVP / EC.5	
Country of Manufacture		Italy	
Nominal Capacity	m ³ /h	5	6
	CFM	2.94	3.53
Final Pressure (Abs)	% Vacuum	90	
	mbar	120	
Motor Power	kW	0.12	0.15
Nominal RPM	n/min	2800	3300
Noise Level (UNI EN ISO 2151 - K - 3db)	dB(A)	59	61
Weight	kg	6.5	
Pump Intake / Outlet Fitting		1/4"G/BSPT	
Continuous Duty Working Range (Abs)	mbar - hPa	Any	
Operating Temperature @ 20°C Ambient	°C	65—70	70—75
Required Room Temperature	°C	0—40	
Ambient Temperature for Storage	°C	-20—50	
Max Humidity / Altitude	% / m s.l.m.	80 / 1000	

Installation

EC5 requires no installation.

The pump is supplied complete with an integrated power switch and IEC socket, with choice of region-suitable power-leads making installation quick and easy; requiring only a standard 13A wall socket.

EC5 is suitable for use in all countries and territories with a 220-240v mains supply. Choose the appropriate regional power-lead when ordering.

Damage Prevention

Inline Filter

The use of an inline filter is highly recommended to prevent ingestion of dust, dirt and stray reinforcement fibres which can contaminate the pump's oil, resulting in premature wear and reduced performance.

Inline Catch-Pot

To prevent accidental resin ingestion, the use of an inline catch-pot (such as the CP1 Resin Infusion Catch-Pot) is essential whenever the pump could be exposed to liquid resins, such as vacuum bagging and especially resin infusion.

Dimensions

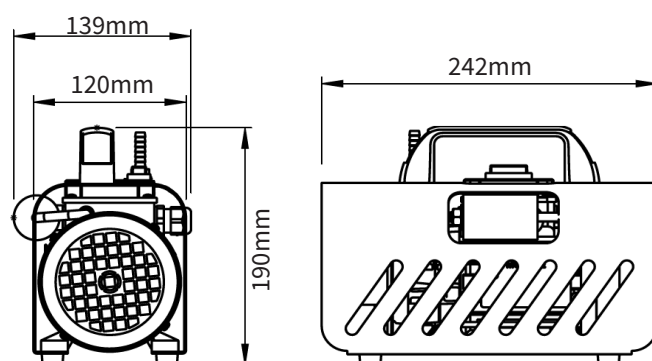

Sold exclusively by Easy Composites

